



Shota Rustaveli
National Science
Foundation



JÜLICH
Forschungszentrum

David Mchedlishvili
(SMART|EDM_lab of TSU)

Work in Tbilisi

GGSWBS'18

23.08.2018, Tbilisi

JEDI: Charged-Particle EDM Search

Main principle:

- Inject polarized particles into a **storage ring**:
- Apply **radial electric field E**:

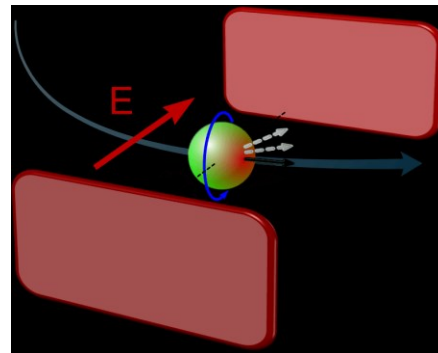
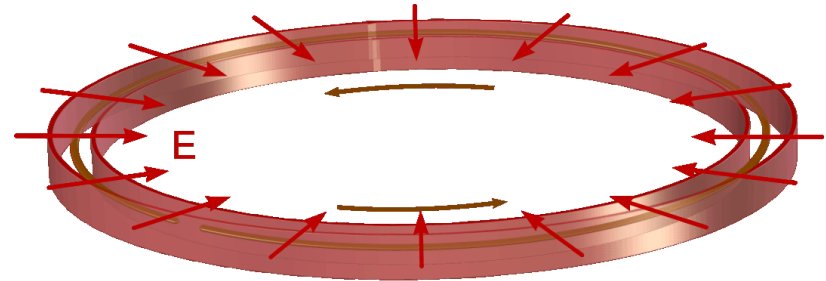

$$\frac{d\vec{s}}{dt} \propto d\vec{E} \times \vec{s}$$

- Non-zero EDM \rightarrow **spin rotation out of the plane**
- Track spin rotation \rightarrow **need precise polarimeter**

JEDI polarimeter

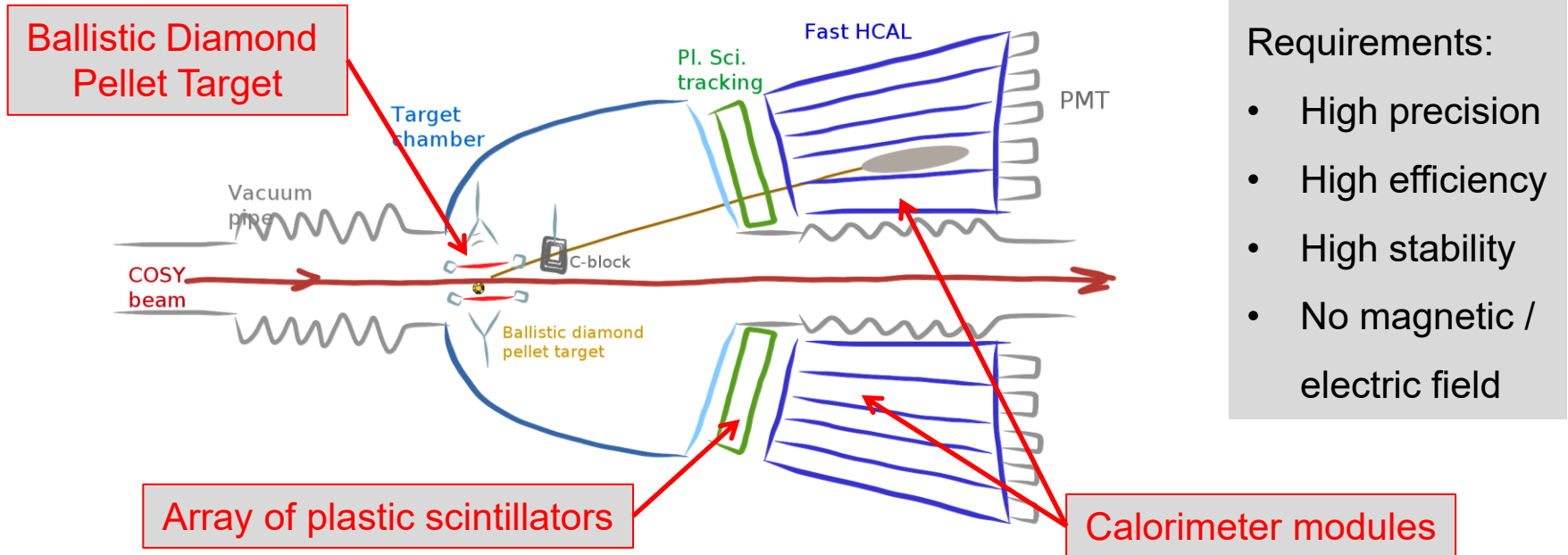

- LYSO based EM calorimeter for highest energy resolution
- Fast plastic scintillators for particle identification
- FADC based readout for fast data acquisition
- New type of target for unprecedented precision

Final design

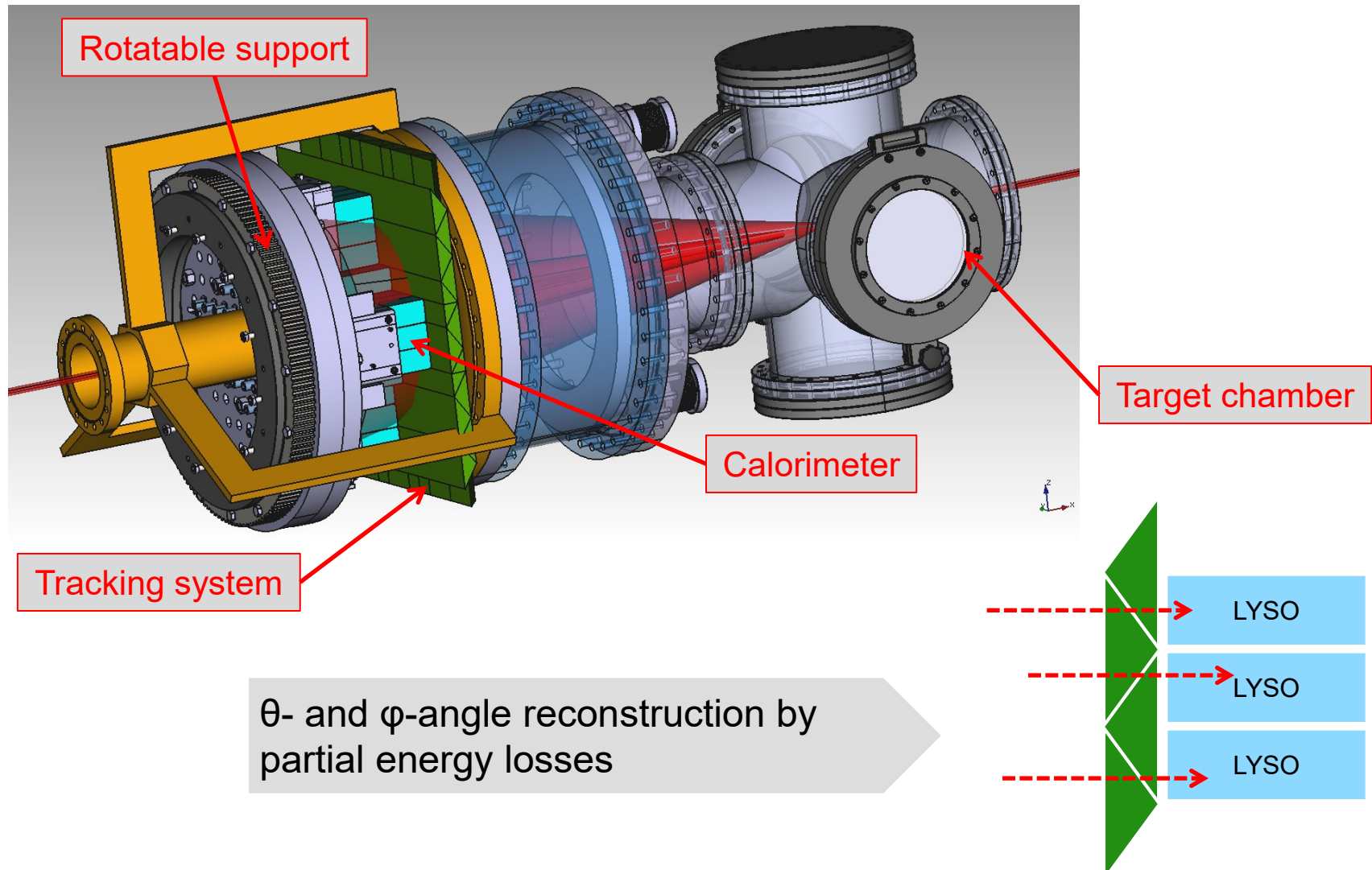

First tests at COSY

First test - 4 LYSO modules

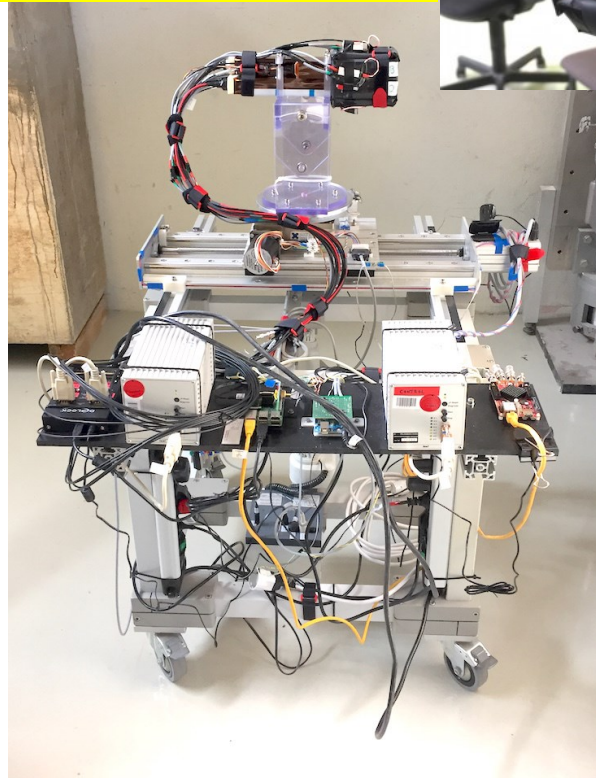
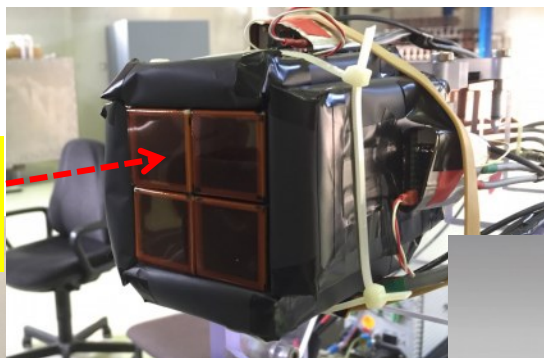

Second test –
24 LYSO modules

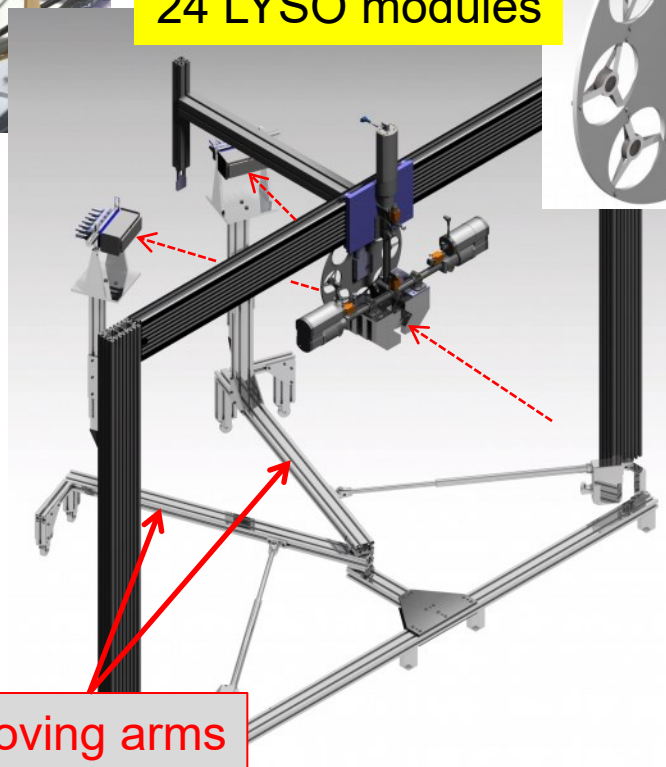

Target wheel

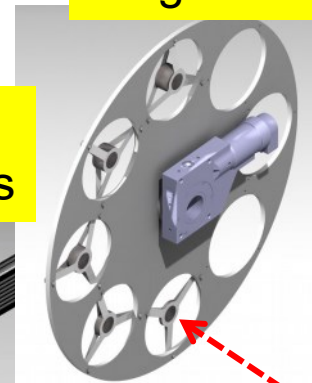

More pictures...

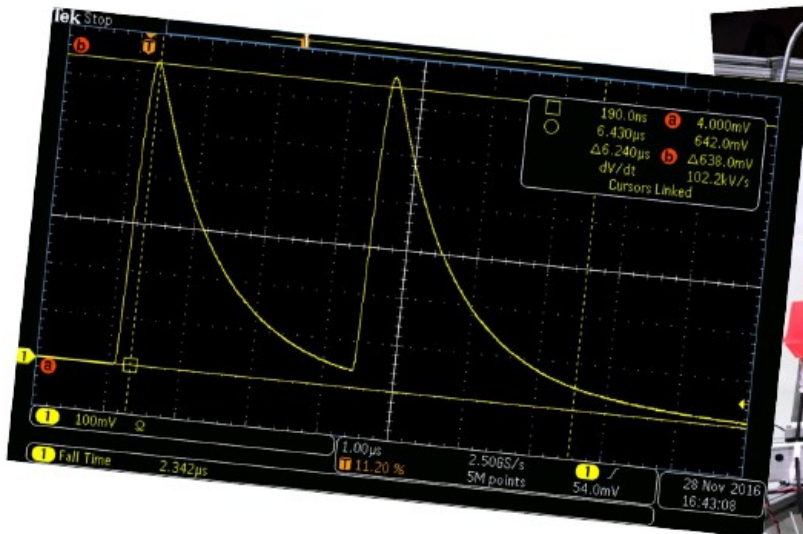
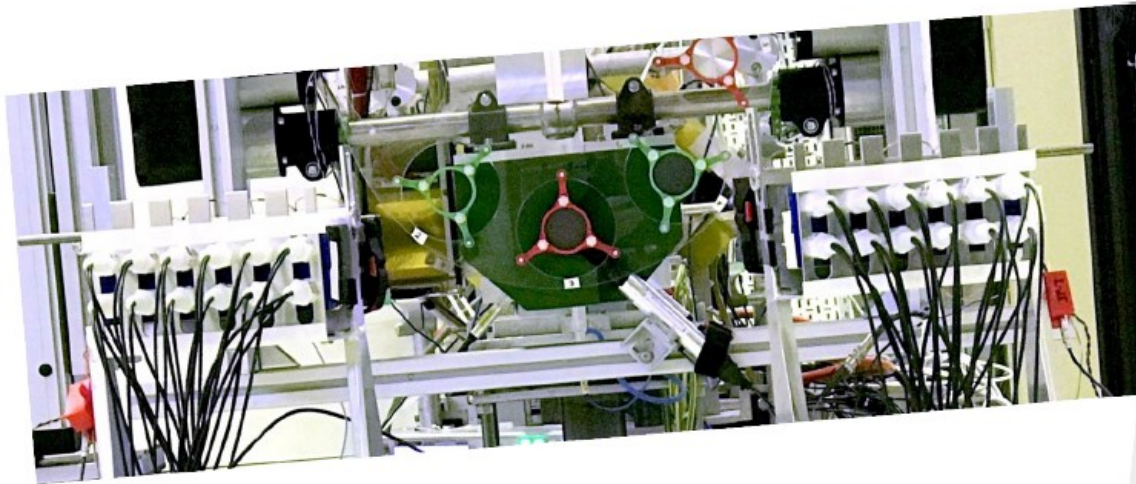

Current test setup

Goals:

- Demonstrate simultaneous operation of 48+ calorimeter modules
- Test LYSO crystals and SiPMs of different manufacturers
- Identify stable operation of SiPM voltage supplies
- Test unemployed capabilities of DAQ hardware
- Test rotatable detector concept

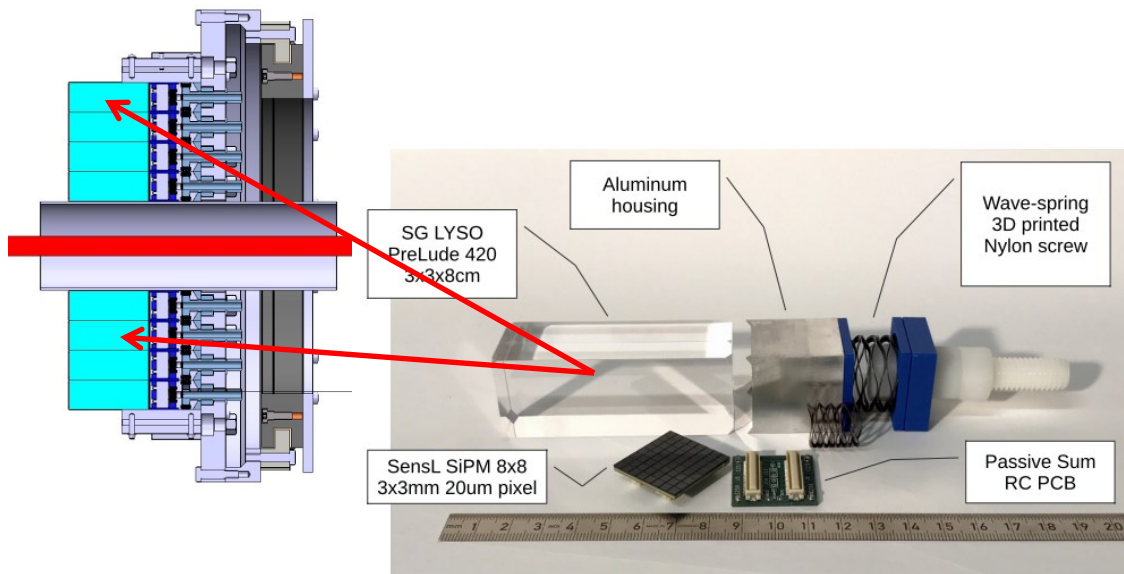
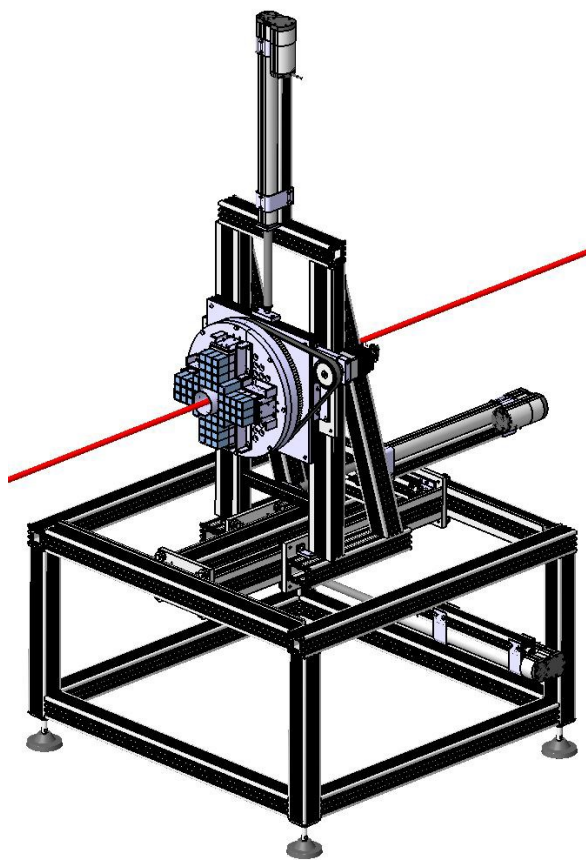

Opening of SMART|EDM_lab at TSU

29.08.2016



- ✓ PhD and Master students involved
- ✓ Well equipped and maintained
- ✓ Strong cooperation with JEDI collaboration
- ✓ Search for and motivate new students

Support:

- Shota Rustaveli National Science Foundation
- Tbilisi State University
- Research Center Jülich (IKP)



What we develop at Tbilisi lab...

1. Precise modular power supplies
2. Voltage monitoring system
3. Data acquisition and online monitoring systems
4. New target development...
5. Offline data analysis
6. Applications...
7. ...

Power supply development

SiPM-based LYSO calorimeter module

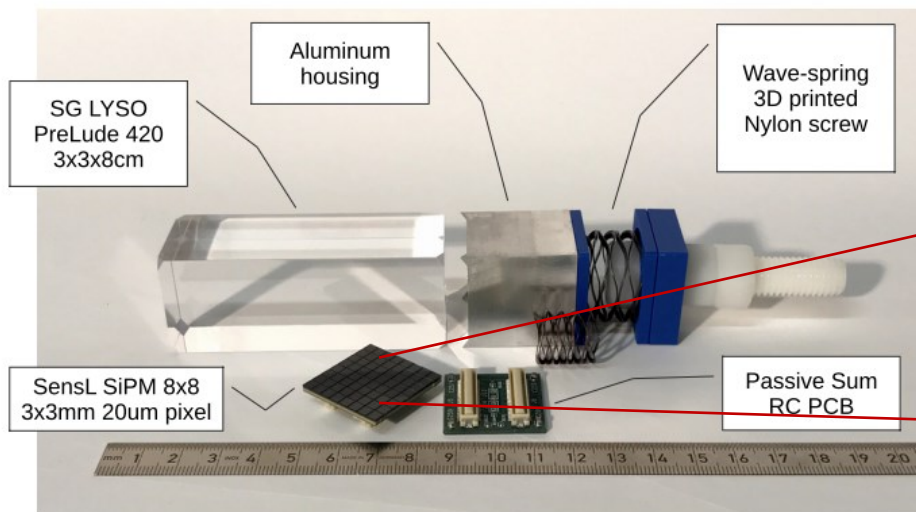

SiPM array

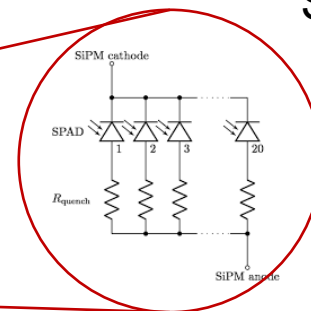

Power supply development

SiPM-based LYSO calorimeter module

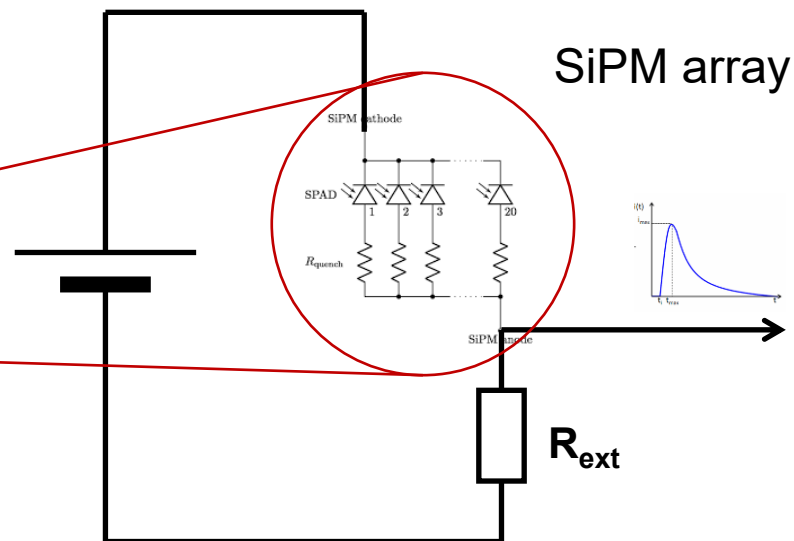
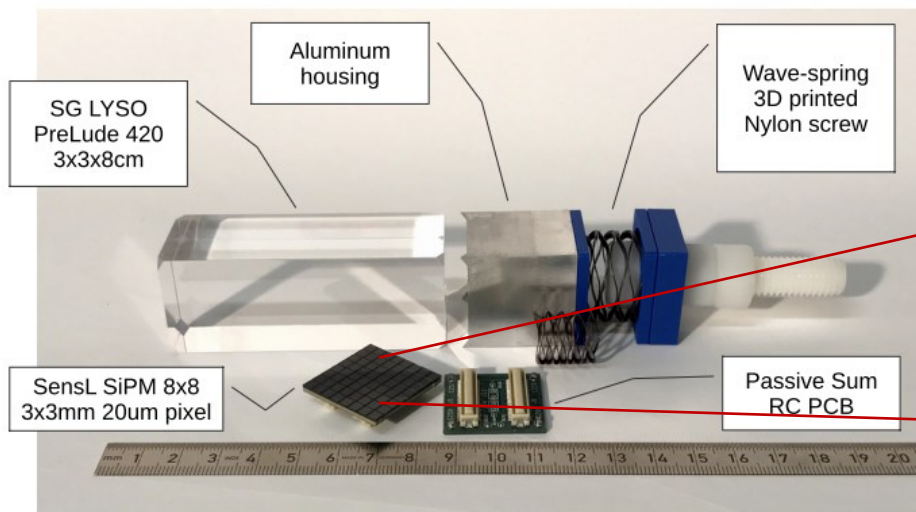

Current demands:

- Internal radiation + dark current: $\sim 10 \dots 30 \mu\text{A}$ (average)
- Single 300 MeV deuteron hit: $\sim 100 \text{ mA}$ (peak)

Power supply development

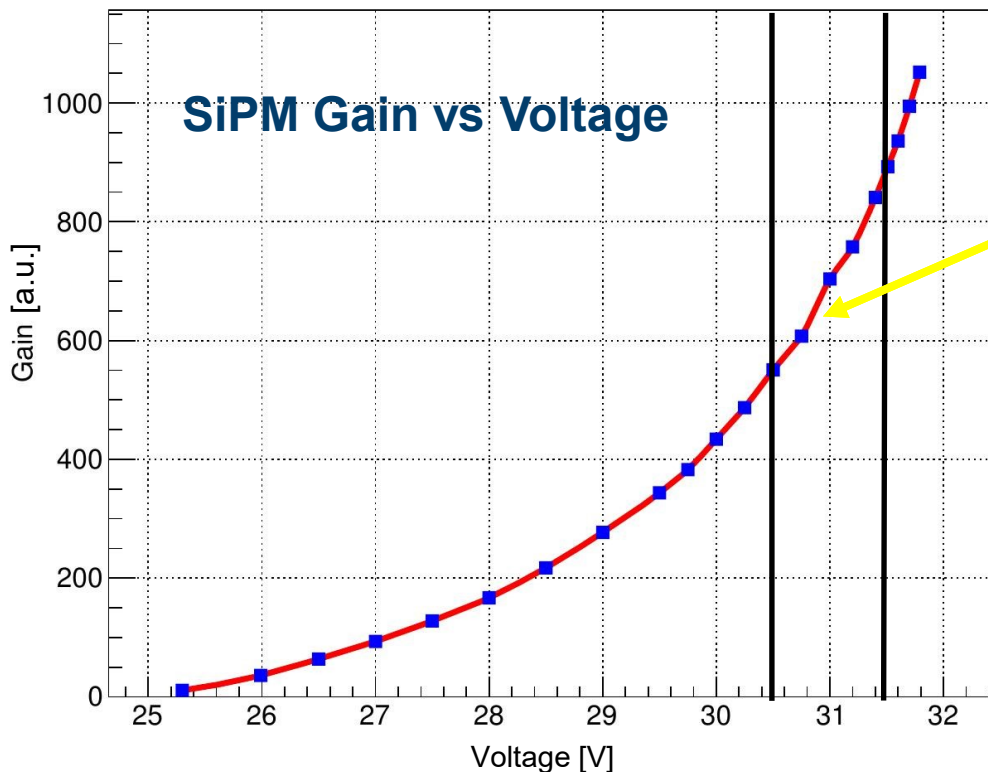

1mV variation ~ 0.02...0.05
% in gain

Main requirements:

- Modular design
- High output stability
(temperature, long/short term, low noise)
- Remote on/off capability
- Voltage adjustment

Details: See talk by Otar Javakhishvili...

Power supply development

Current status...

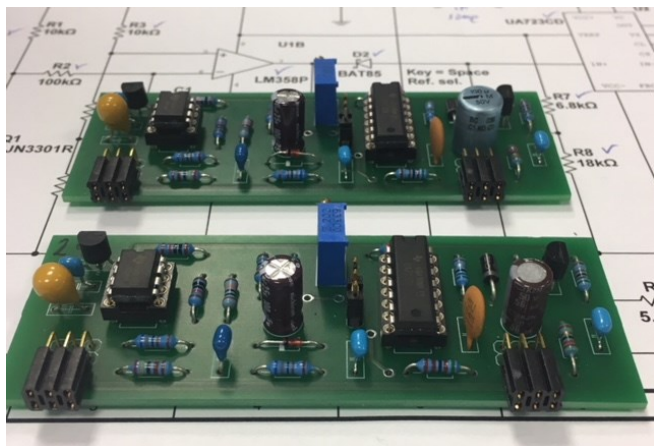

- ✓ 64 channel supply built
- ✓ 128 channel voltage monitoring system developed and tested
- ✓ Continues voltage monitored during the run

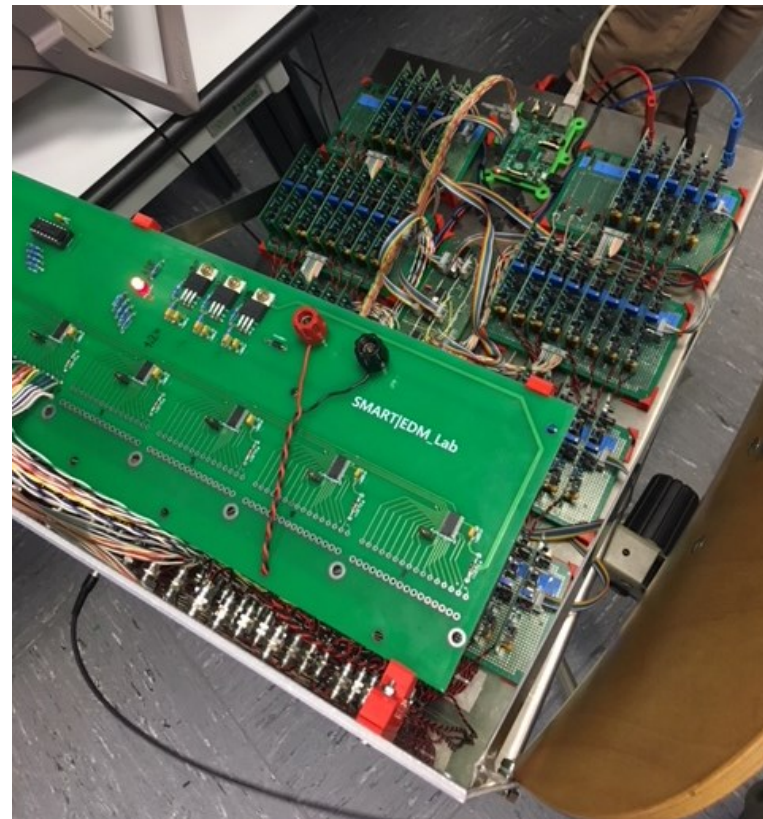

Details: See talk by Otar Javakhishvili...

Data acquisition and online analysis

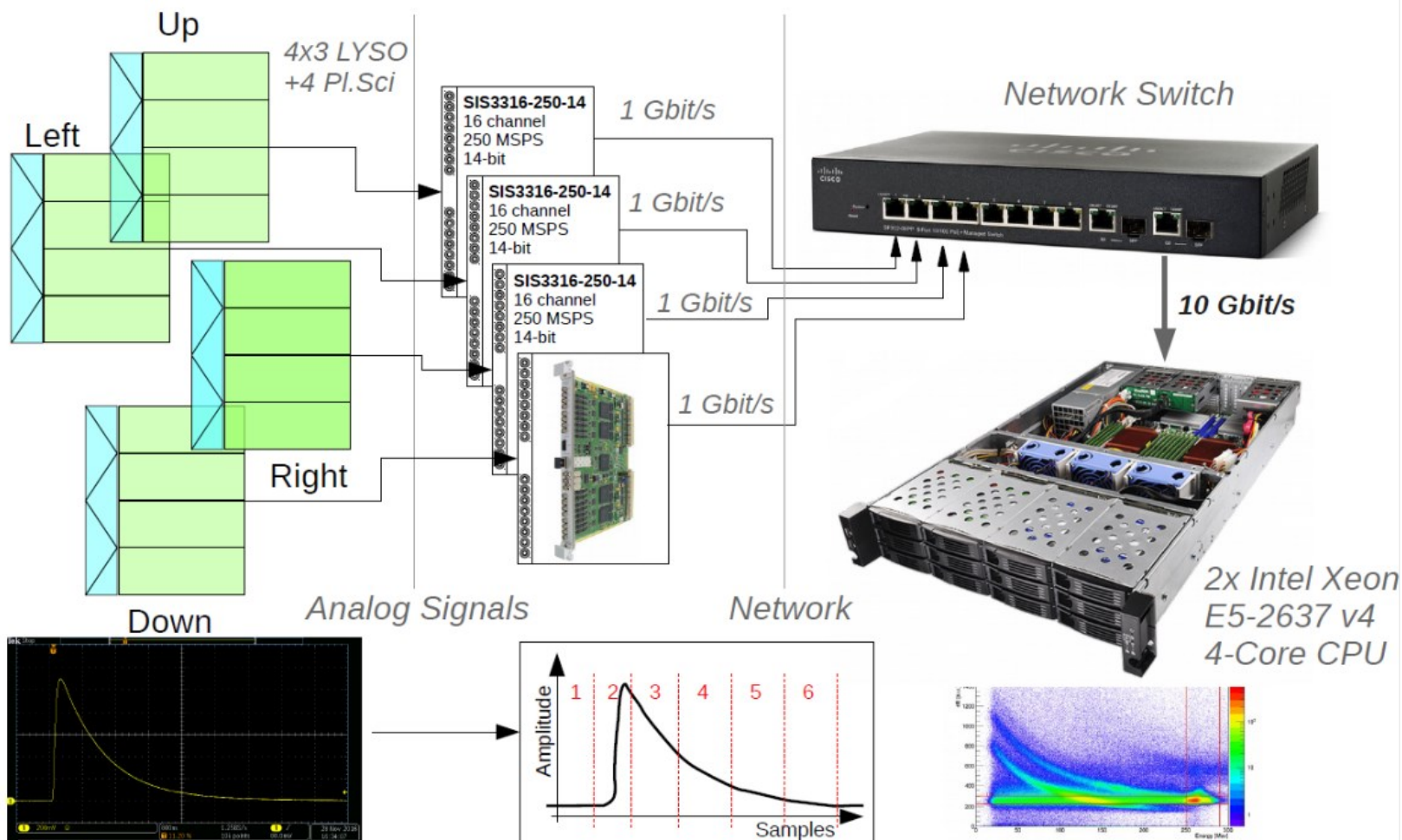

Details: See talk by Dito Shergelashvili...

Data acquisition and online analysis

Hardware - Based on Struck Sis3316 FADCs

- 16 ch/module
- 250 MS/s, 14 bit
- FPGA-based
- Data buffering, two large memory banks
(almost dead time-free)
- Configuration, data acquisition via LAN
- Internal/external triggering
- Integrated CFD feature → Much more precise
relative timing (~50 ps!)
- Easily scalable; clock synchronization possible!



Data acquisition and online analysis

Triggering and acquisition schemes:

1. Common trigger, sequential module readout

- Simple event reconstruction
- No precise timing
- Big amount of data (empty channels recorded!)
- Low rate

2. Internal (individual) trigger, sequential module readout

- Precise timing
- Small amount of data
- Moderate rate
- Complex event reconstruction

3. Internal trigger, parallel module readout

- Precise timing
- Small amount of data
- Highest rate!!!
- Most complex event reconstruction

Software must handle all these operation modes...

Data acquisition and online analysis software

Details: See talk by Dito Shergelashvili...

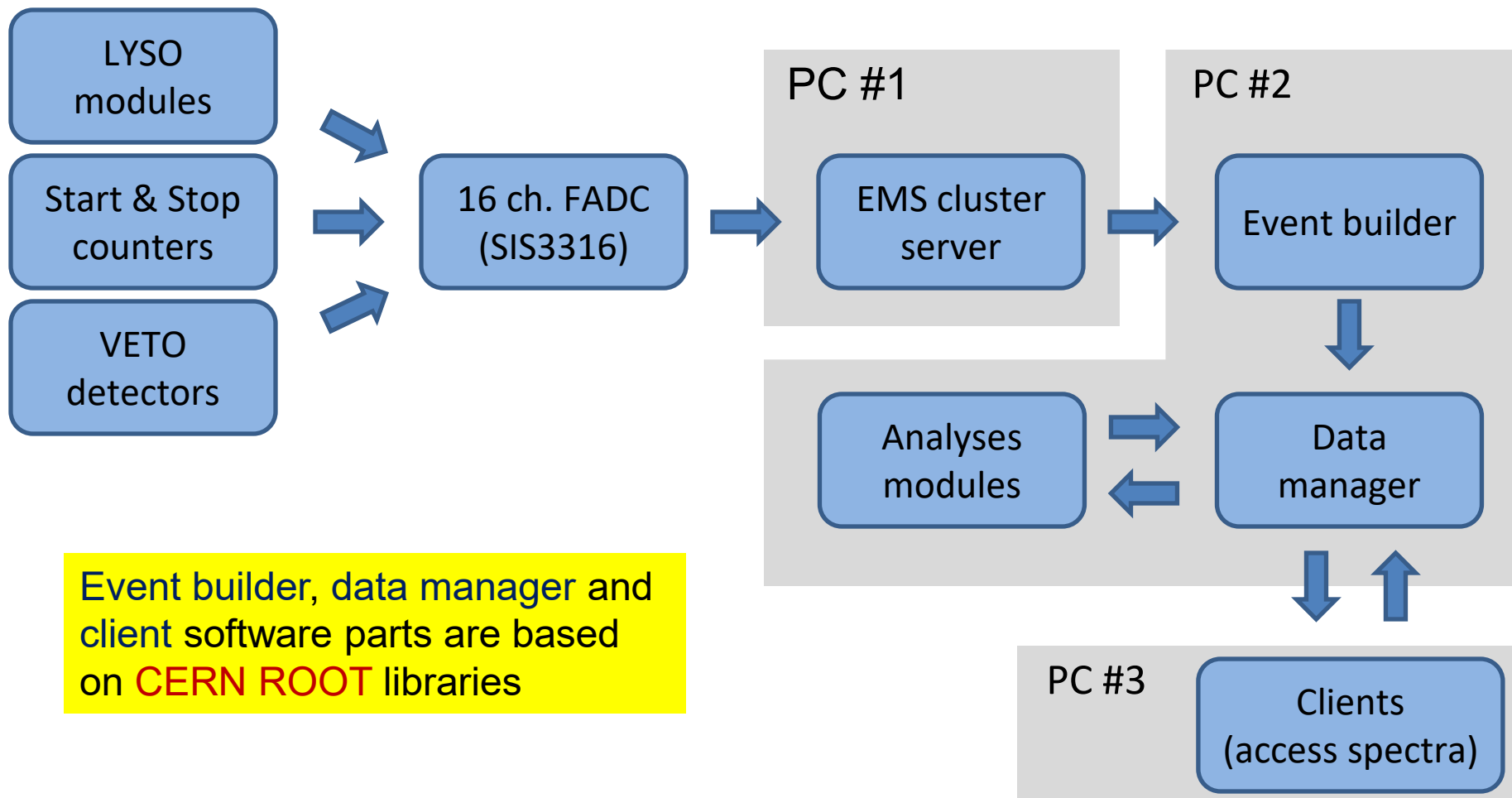

Online data analysis

Details: See talk by Dito Shergelashvili...

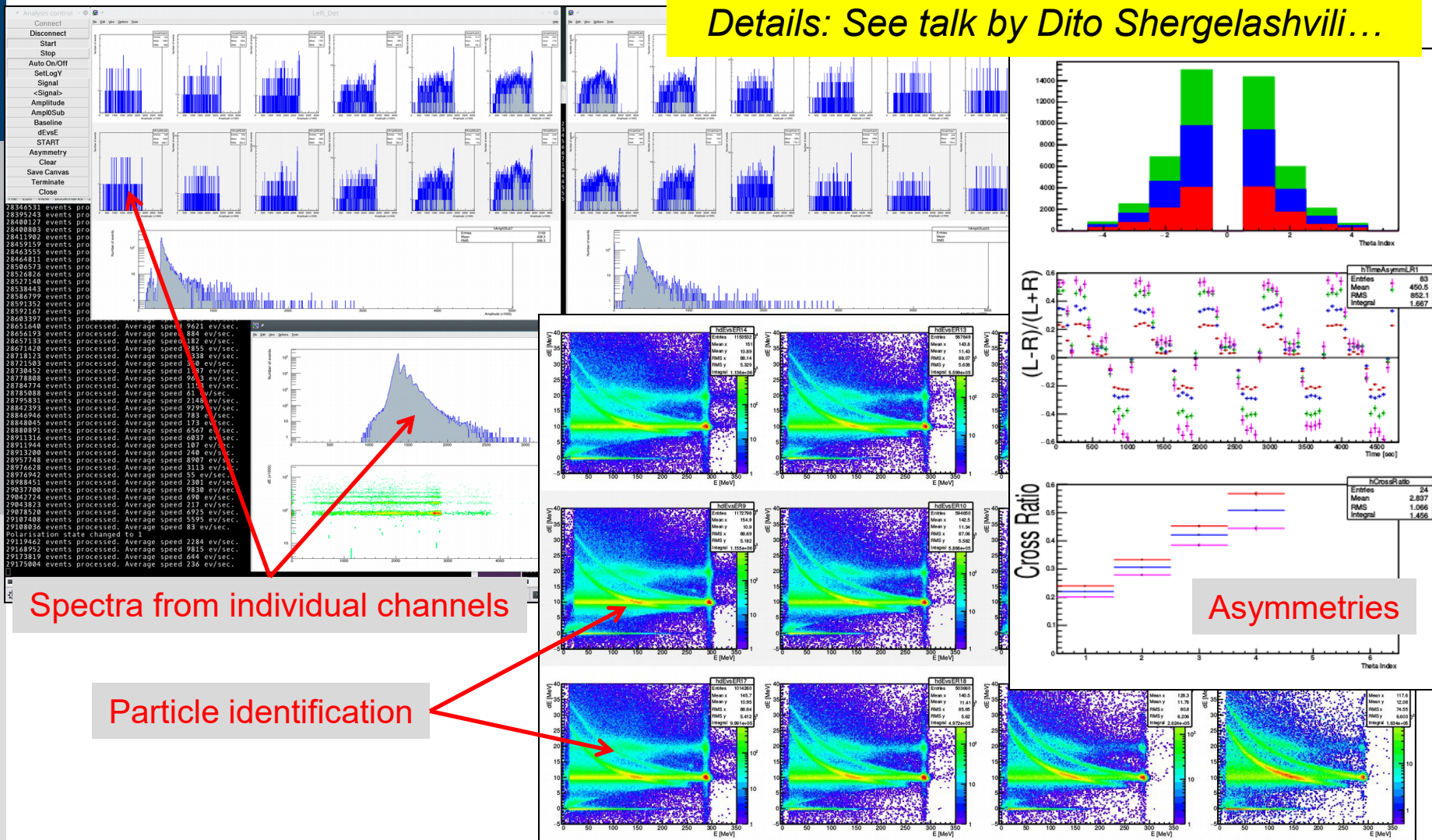



Summary

- ✓ First version of 64 ch voltage supply built and tested
- ✓ Independent 128 ch voltage monitoring system developed – Data taken during recent test-experiments
- ✓ Online event reconstruction and data analysis software development follows detector evolution
- ✓ Successful Masters thesis defense (by Otar Javakhishvili)

Outlook

- Further development of voltage supplies – version 2
- Software development: improve parallelism, implement new tracking system, create GUI interface, ...



Thank you