

Measurement of the analysing power in proton-proton elastic scattering at small angles

Z. Bagdasarian^{a,b,*}, D. Chiladze^{a,b}, S. Dymov^{c,b}, A. Kacharava^b, G. Macharashvili^{a,c}, S. Barsov^d, R. Gebel^b, B. Gou^{e,b}, M. Hartmann^b, I. Keshelashvili^b, A. Khoukaz^f, P. Kulesha^g, A. Kulikov^c, A. Lehrach^b, N. Lomidze^a, B. Lorentz^b, R. Maier^b, D. Mchedlishvili^{a,b}, S. Merzliakov^{c,b}, S. Mikirtychyants^{b,d}, M. Nioradze^a, H. Ohm^b, M. Papenbrock^f, D. Prasuhn^b, F. Rathmann^b, V. Serdyuk^b, V. Shmakova^c, R. Stassen^b, H. Stockhorst^b, I.I. Strakovsky^h, H. Ströher^b, M. Tabidze^a, A. Täschner^f, S. Trusov^{i,j}, D. Tsirkov^c, Yu. Uzikov^c, Yu. Valdau^{d,k}, C. Wilkin^l, R.L. Workman^h

^aHigh Energy Physics Institute, Tbilisi State University, GE-0186 Tbilisi, Georgia

^bInstitut für Kernphysik, Forschungszentrum Jülich, D-52425 Jülich, Germany

^cLaboratory of Nuclear Problems, JINR, RU-141980 Dubna, Russia

^dHigh Energy Physics Department, Petersburg Nuclear Physics Institute, RU-188350 Gatchina, Russia

^eInstitute of Modern Physics, Chinese Academy of Sciences, Lanzhou 730000, China

^fInstitut für Kernphysik, Universität Münster, D-48149 Münster, Germany

^gH. Niewodniczański Institute of Nuclear Physics PAN, PL-31342 Kraków, Poland

^hData Analysis Center at the Institute for Nuclear Studies, Department of Physics,

The George Washington University, Washington, D.C. 20052, USA

ⁱInstitut für Kern- und Hadronenphysik, Forschungszentrum Rossendorf, D-01314 Dresden, Germany

^jDepartment of Physics, M. V. Lomonosov Moscow State University, RU-119991 Moscow, Russia

^kHelmholtz-Institut für Strahlen- und Kernphysik, Universität Bonn, D-53115 Bonn, Germany

^lPhysics and Astronomy Department, UCL, London WC1E 6BT, UK

Abstract

The proton analysing power in $\vec{p}p$ elastic scattering has been measured at small angles at COSY-ANKE at 796 MeV and five other beam energies between 1.6 and 2.4 GeV using a polarised proton beam. The asymmetries obtained by detecting the fast proton in the ANKE forward detector or the slow recoil proton in a silicon tracking telescope are completely consistent. Although the analysing power results agree well with the many published data at 796 MeV, and also with the most recent partial wave solution at this energy, the ANKE data at the higher energies lie well above the predictions of this solution at small angles. An updated phase shift analysis that uses the ANKE results together with the World data leads to a much better description of these new measurements.

Keywords:

Proton-proton elastic scattering, analysing power, phase shift analysis

PACS: 13.75.Cs, 24.70.+s, 25.40.Cm

The measurements of proton-proton elastic scattering undertaken by the COSY-EDDA collaboration have had a major impact on the partial wave analysis of this reaction above 1 GeV [1]. The data on the differential cross section [2] were taken in a continuous ramp from 0.24 to 2.58 GeV and analogous results were produced for the proton analysing power between 0.44 and 2.49 GeV [3]. In addition, pp spin correlations were studied between 0.48 and 2.49 GeV [4]. However, due to the design of the EDDA detector, the experiments only extended over the central region of centre-of-mass (c.m.) angles, $30^\circ \lesssim \theta_{cm} \lesssim 150^\circ$, and there are very few other analysing power measurements available below 30° for beam energies above 1 GeV [1]. The lack of data has left major ambiguities in the phase shift analysis. In complete contrast to COSY-EDDA, the COSY-ANKE facility was designed for the investigation of the small angle region and is thus well suited to cover this significant gap in the database.

The present experiment was carried out using the ANKE

magnetic spectrometer [5] positioned inside the storage ring of the COoler SYnchrotron (COSY) [6] of the Forschungszentrum Jülich. Although the facility sketched in Fig. 1 is equipped with other elements, the only detectors used in this experiment were the forward detector (FD) and the silicon tracking telescopes (STT) [7].

The fast protons from elastic pp scattering were measured in the forward detector which, for pp elastic scattering, covered $10^\circ - 30^\circ$ in c.m. polar angles and $\pm 30^\circ$ in azimuth. The FD comprises a set of multiwire proportional and drift chambers (MWCs) and a two-plane scintillation hodoscope. The counters were used to measure the energy losses required for particle identification [8].

The two STT were placed symmetrically inside the vacuum chamber, to the left and right of the beam near the unpolarised hydrogen cluster-jet target [9]. Each telescope consists of three sensitive silicon layers of 70 μm , 300 μm , and 5 mm thickness and covers the laboratory polar angles $75^\circ < \theta_{lab} < 140^\circ$. In order to pass through the three layers, the protons must have kinetic energies of at least 2.5 MeV, 6 MeV, and 30 MeV, re-

*Corresponding author.

Email address: z.bagdasarian@fz-juelich.de (Z. Bagdasarian)

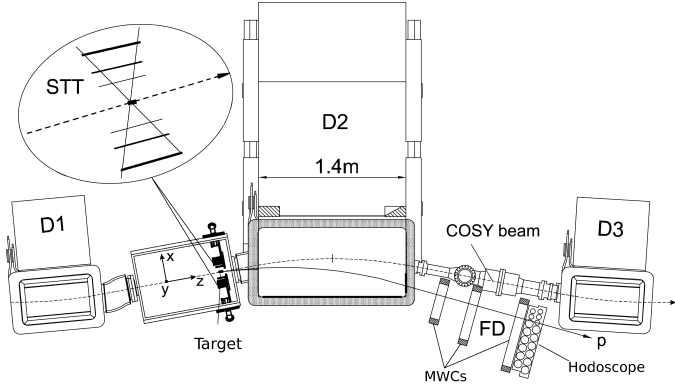

Figure 1: The ANKE spectrometer setup (top view), showing the positions of the hydrogen cluster-jet target, the silicon tracking telescopes (STT), and the forward detector (FD).

spectively. For stopping protons with energies below 30 MeV the particle identification is unambiguous. In this case greater precision in the angle of the recoiling proton is achieved by deducing it from the energy measured in the telescope rather than from a direct angular measurement. However, by studying the energy deposited principally in the third layer, it is also possible to deduce the energy of punch-through protons up to 90 MeV, thus expanding considerably the angular coverage of the telescope. For this purpose the kinetic energy of these fast protons was defined through a comparison of the angles and energy deposits with simulated data using a neural network approach [10].

Two independent triggers were used in the determination of the analysing powers. The FD trigger required a coincidence between the two planes in the hodoscope while the STT trigger requested a minimum energy deposit in the second layer of either telescope. Due to the overlap in the angular acceptance, some events were registered with both triggers. However, since the two data sets were then analysed independently, this did not bias the either set of results.

The ANKE experiment used a vertically polarised beam incident on an unpolarised target so that the preparation and the measurement of the beam polarisation are critical. The H^- ions from the polarised ion source were accelerated to 45 MeV in the cyclotron JULIC before being stripped of their electrons and injected into COSY [11]. Two modes, with spin up (\uparrow) and down (\downarrow), were supplied by the source and the polarisations of the injected beam were optimised using a low energy polarimeter (LEP) in the injection beam line to COSY [12]. The LEP measurements showed that the magnitudes of the polarisations were typically about 93% and the difference between the values of the two modes was smaller than the statistical uncertainty of 1%.

In a strong-focusing synchrotron, such as COSY, resonances can lead to losses of polarisation of a proton beam during acceleration. In order to compensate for these effects, adiabatic spin-flip was used to overcome the imperfection resonances and tune-jumping to deal with the intrinsic ones [13]. The polarisations were measured using the EDDA detector as a polarimeter.

This detector, originally equipped with a polarised hydrogen target, had been used to measure the pp analysing power over almost the whole COSY energy range [3]. By studying further the scattering of polarised protons on C and CH_2 targets, it was possible to deduce the quasi-free analysing power of the carbon, where the necessary calibration standard was provided by the EDDA $p\vec{p}$ data [14].

The stripped-down version of the EDDA detector used as a polarimeter at COSY was calibrated during the EDDA data-taking periods against the full detector setup. The $7\ \mu\text{m}$ diameter carbon fibre target is moved into the beam from below. The polarimeter consists of 29 pairs of half-rings placed to the left and right of the beam. It is therefore possible to compare the rates in the left and right half-rings for each range in polar angle θ_{lab} while averaging over the azimuthal angle ϕ in every half-ring. In order to assure fast polarimetry, the coincidences are recorded by scalars. The asymmetry is determined individually for each pair of half-rings and the weighted average evaluated. The systematic uncertainty of the measurements was estimated to be 3% at each energy [14].

The experiment at ANKE was carried out at six energies, $T_p = 796, 1600, 1800, 1965, 2157,$ and 2368 MeV. Cycles of 180 s or 300 s duration were used for each spin mode, with the last 20 s of each cycle being reserved for the measurement of the beam polarisation with the EDDA detector¹. Consistent results were achieved with EDDA after the short and long cycles which, as expected, implies that beam polarisation is not lost over a COSY cycle. However, due to the non-zero dispersion combined with the energy loss of the beam caused by its passage through the target, the settings at the three lowest energies gradually degrade slightly. This effect was taken into account in the analysis.

Table 1: The values of the mean polarisations p determined with the EDDA polarimeter averaged over all the data at the beam energy T_p where the pp analysing power was measured in ANKE. The changes in sign in p are due to the spin flips induced when passing through the imperfection resonances. Though the shown statistical errors are small, there are 3% systematic uncertainties [14]. The normalisation factors N are those obtained in a partial wave fit [1] to the current STT data, as discussed in the text.

T_p (MeV)	796	1600	1800	1965	2157	2368
p	0.554 ± 0.008	0.504 ± 0.003	-0.508 ± 0.011	-0.429 ± 0.008	-0.501 ± 0.010	0.435 ± 0.015
N	1.00	1.00	0.99	1.09	1.01	0.93

The weighted averages over time and polar angle of the beam polarisations determined using the EDDA polarimeter at the six energies are given in Table 1. The values correspond to half the difference between spin up and down data and the changes in sign reflect the number of spin flips required to pass through the imperfection resonances. The variation of the beam polarisation cycle by cycle was checked with the asymmetry of the counts in STT and found to be around 0.04 (RMS). It should be noted that, even for the lowest energy of 796 MeV, two intrinsic and two imperfection resonances have to be crossed dur-

¹The EDDA target effectively consumes all the beam so that it could not be used before an ANKE measurement in a cycle.

ing the acceleration and this results in polarisations of less than 60% for all the energies investigated. At each of these six energies the beams were prepared independently and, for this reason, the magnitude of the polarisation may not decrease monotonically as more resonances are crossed.

In the ANKE experiment a proton is measured in either the STT or FD and elastic pp scattering events identified through the evaluation of the missing mass in the reaction. As can be seen from typical examples of both cases shown in Fig. 2 at a beam energy of 1.6 GeV, there is very little ambiguity in the isolation of the proton peak. The greater suppression of events associated with pion production in the STT is due to the minimum longitudinal momentum of the recoil proton and the restricted angular acceptance of this detector.

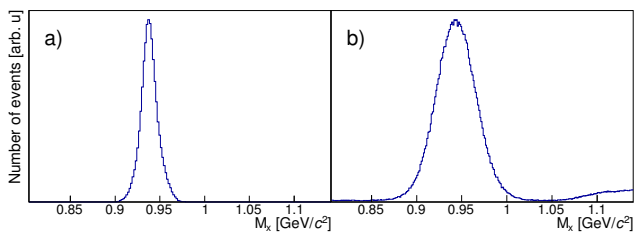

Figure 2: Missing-mass $M_X(pp \rightarrow pX)$ spectra obtained for a beam energy of 1.6 GeV showing the clear proton peak when detecting one proton in (a) the STT and (b) the FD.

The left/right symmetry of the STT system reduces some of the systematic uncertainties. The so-called cross-ratio method [15] allows one to eliminate first-order systematic errors that arise from misalignments between the two STT and for this reason the beam polarisation was reversed in each successive cycle. Let $L_\uparrow(L_\downarrow)$ be the numbers of counts in the left telescope with spin up (down) and $R_\uparrow(R_\downarrow)$ the analogous quantities for the right telescope. In terms of the geometric means, $L = \sqrt{L_\uparrow R_\downarrow}$ and $R = \sqrt{R_\uparrow L_\downarrow}$, the scattering asymmetry is related to the analysing power $A_y(\theta)$ for each value of the scattering angle θ through

$$\varepsilon(\theta) = \frac{L(\theta) - R(\theta)}{L(\theta) + R(\theta)} = A_y(\theta) p \langle \cos \phi \rangle, \quad (1)$$

where $p \langle \cos \phi \rangle$ is the effective beam polarisation, taking into account the acceptance of the STT in the azimuthal angle ϕ . In our geometry $\langle \cos \phi \rangle \approx 0.966$.

Other systematic errors, such as those arising from differences in the magnitudes of the up and down polarisations, also cancel in first order. The overall systematic uncertainty in A_y arising from asymmetry measurement with STT does not exceed 0.3%. Another factor that could affect the asymmetry measured with such a two-arm detector is any instability in the ratio of the efficiencies of the left and right telescopes. The instability correction, which was studied at all energies, does not exceed the $|c| = 1.3\%$ that was found at 1.8 GeV. The relevant corrections of the analysing power $c(\theta)A_y(\theta)$ were added for each angular bin [10].

The absence of the left-right symmetry in the forward detector does not permit the use of the cross-ratio method, and the analysing power can only be defined from the asymmetry of

the count-rates for the two states of the beam polarisation. The number of events for each orientation of the polarisation was weighted with the relative luminosity factors, which were fixed by comparing the rates of charged particle production in angular regions where the beam polarisation could play no part [16]. Since the calibration events were selected with the same trigger as that used for pp elastic scattering, this procedure automatically takes into account any dead-time difference between the spin-up and spin-down data. The calibration data, which corresponded generally to inelastic events involving pion production, were selected by putting cuts either on small polar angles θ or on the azimuthal angle ϕ near $\pm 90^\circ$. Consistent values for the relative luminosities were achieved when varying these cuts and it is estimated that the systematic uncertainty of A_y due to the relative luminosity normalisation never exceeds 0.3%. This approach could be checked by comparing the FD and STT results in the angular overlap regions.

The efficiency for registering events in the forward detector induced by spin-up or spin-down protons was studied by using events where both the fast and recoil protons were measured in the FD and STT, respectively. The differences of the efficiencies of less than 10^{-3} could be neglected compared to the statistical uncertainties. Potentially more serious for the FD analysis is the assumption that the magnitudes of the two polarisation modes were identical, viz. $|p_\uparrow| = |p_\downarrow|$. Whereas deviations from the mean are very small at injection, and are known to be less than 5% after acceleration, these could induce fractional errors in A_y of up to 2.5%. It should, however, be remarked that in the overlap regions of the STT and FD data any disagreements between the determinations of the asymmetries in the two systems are on the 1% level and this puts a much tighter constraint on possible $|p_\uparrow|$, $|p_\downarrow|$ differences.

There is also a systematic uncertainty in the determination of the scattering angle, and this could affect both the STT and FD data. The simultaneous measurement of the deuteron and pion from the $pp \rightarrow d\pi^+$ reaction in the forward detector showed that the systematic deviations in the laboratory angles from those expected for these kinematics did not exceed 0.07° . If this is valid also for pp elastic scattering it would suggest that the c.m. scattering angles were defined with a precision of better than 0.15° .

In cases where one of the protons from an elastic scattering event is detected in the FD and the other in the STT it is possible to compare directly the scattering angle measured in the two systems. In general $\theta_{cm}(\text{STT}) > \theta_{cm}(\text{FD})$, with the difference being typically $\approx 0.3^\circ$. It is not possible to judge which detector is responsible for this difference which is, however, small compared with the bin widths of 1.0° (FD) and 1.2° (STT).

The dominant systematic error is that arising from the determination of the beam polarisation in the EDDA polarimeter, which was estimated to be 3% [14]. For the FD data there is, in addition, a possible contribution associated with the assumption of equal up and down polarisations so that in this case we would cautiously assume a 5% systematic uncertainty. To these figures must be added the statistical uncertainty in the determinations of the beam polarisations at the six energies shown in Table 1.

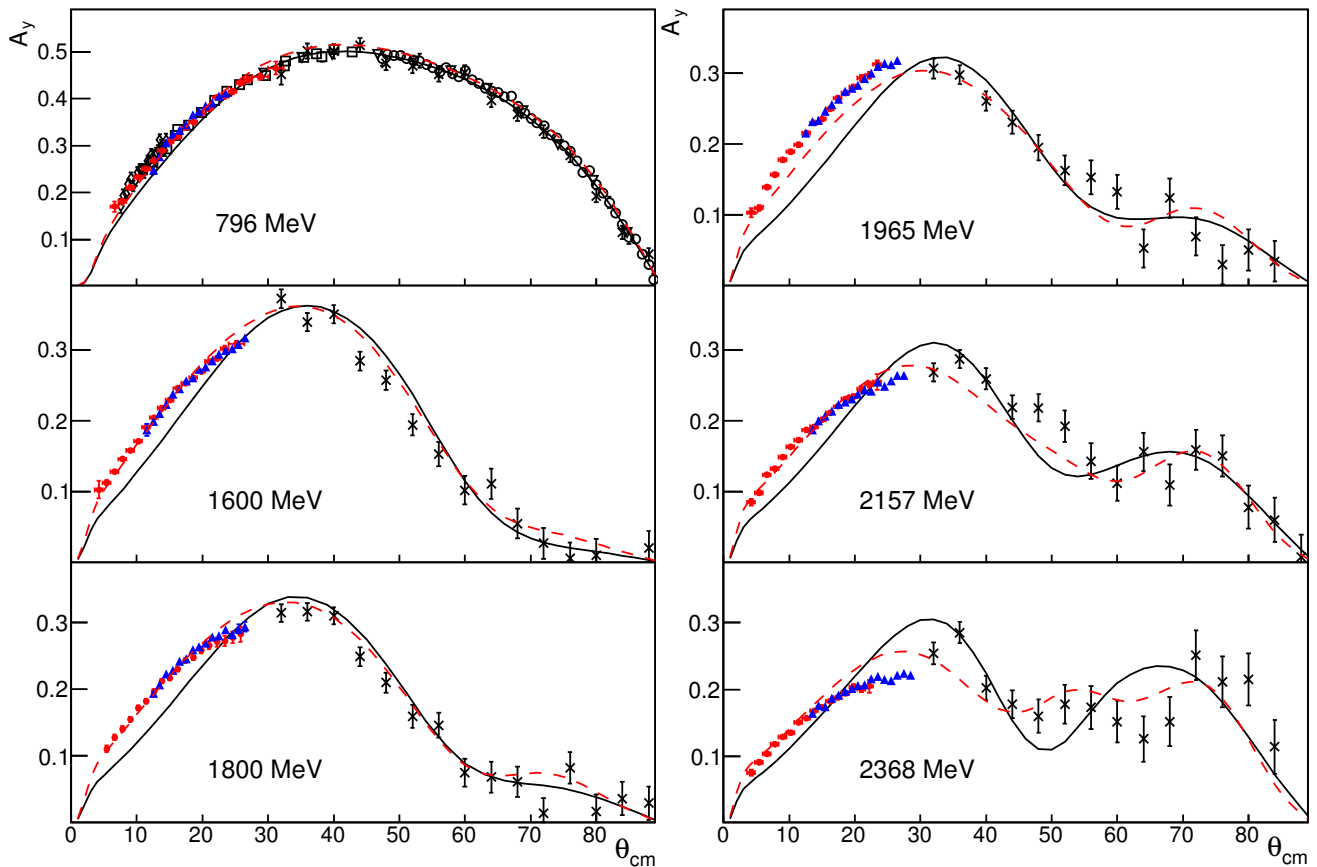

Figure 3: (Color online) Comparison of the ANKE measurements of the proton analysing power in pp elastic scattering using the STT (red filled circles) and FD (blue filled triangles) systems with the curves corresponding to the SAID SP07 (solid black line) and the revised fit (dashed red) solutions [1]. Only statistical errors are shown so that the systematic uncertainties arising, for example, from the calibration of the EDDA polarimeter have not been included. Also shown are selected results from EDDA (black crosses) [3] at the energies different by no more than 7 MeV and, at 796 MeV, LAMPF [17, 18, 19], and SATURNE [20] (black open symbols). It should be noted that the EDDA data were taken over a continuous ramp [3] and, if continuity in energy were imposed, many of their statistical fluctuations would be diminished.

The results of all the ANKE measurements of A_y for pp elastic scattering are shown for the six energies in Fig. 3. The agreement between the STT and FD data, which involved completely independent measurements of the final state, is remarkably good. The individual deviations generally lie within the statistical error bars and the average over the angular overlap regions is $A_y(\text{FD})/A_y(\text{STT}) = 1.00 \pm 0.01$. At beam energies close to 796 MeV there are many measurements of the pp analysing power and, in general, they are in good mutual agreement, as they are with the new ANKE data. This reinforces the confidence in the use of the EDDA polarimeter. At 1.6 GeV and above there are far fewer experimental measurements and, for clarity, we only show the EDDA data at neighbouring energies though, at the highest energy, the statistical fluctuations are significant [3].

The SAID SP07 solution [1], shown by the solid black line in Fig. 3, describes the bulk of the ≈ 796 MeV data very well indeed. However, at higher energies the ANKE data deviate significantly from the predictions of the SP07 solution. Moreover, the shapes of the ANKE data seem very different from these predictions, rising much more steeply at small angles.

Therefore, these discrepancies cannot be due to a simple miscalibration of the EDDA polarimeter, for example, which would change the overall magnitude of $A_y(\theta)$ but not its angular dependence.

The ANKE analysing power data have been added to the World data set and searches made for an updated partial wave solution [1]. To allow for possible systematic effects, the SAID fitting procedure introduces a scale factor N into any data set and determines its value, as well as the pp phases and inelasticities, by minimising an overall χ^2 for the complete data set. When this is done, the average value of χ^2 per degree of freedom found for the ANKE STT data is 1.6 and slightly larger for the FD results. The new fits, which lead to the red dashed curves in Fig. 3, correspond to relatively modest changes to the parameters for several of the lower partial waves, with the biggest change being in 3F_2 . The values of the normalisation factors N reported in Table 1 have an average of $\langle N \rangle = 1.00 \pm 0.02$ for the STT data. These factors, which would effectively multiply the beam polarisations, have not been applied in Fig. 3. The deviations of the individual values of N from unity might seem to be greater at the higher energies. They are somewhat larger than

what one would expect on the basis of the quoted uncertainties in the EDDA polarimeter, being around 5% rather than the 3% estimate [14]. It should be stressed that the introduction of the scale factor N does not change the shape of a distribution and, even in cases where a value close to one is found, this does not mean that the fit reproduces perfectly the data. A clear example of this is to be found in the larger angle data at 1.6 GeV shown in Fig. 3.

In summary we have measured the analysing power in pp elastic scattering at 796 MeV and at five energies from 1.6 GeV up to 2.4 GeV using both the silicon tracking telescopes and the ANKE forward detector. The consistency between these two independent measurements of the final protons is striking so that the only major systematic uncertainty is the few percent associated with the calibration of the EDDA polarimeter. Though the overall uncertainties are slightly larger for the FD data, these results are important because they extend the coverage to slightly larger scattering angles.

In the small angle range accessible to ANKE, the new data are consistent with older measurements around 796 MeV and also with the SP07 SAID predictions at this energy [1]. At higher energies the ANKE results lie significantly above the SP07 solution near the forward direction and also display a different angular dependence. By adjusting some of the phases and inelasticities in the low partial waves of this solution it has been possible to obtain a much better description of the ANKE A_y data with reasonable values of χ^2/NDF . However, this is at the expense of introducing renormalising factors that deviate from unity by more than expected on the basis of the estimated systematic uncertainties arising from the use of the EDDA polarimeter. The situation may be changed somewhat when the corresponding unpolarised differential cross sections [21] become available since these data, which cover rather unexplored regions, might modify the parameters of the “best” partial wave solution. These ANKE data are still being processed.

We acknowledge valuable discussions with Frank Hinterberger. We also are grateful to other members of the ANKE Collaboration for their help with this experiment and to the COSY crew for providing such good working conditions. This work has been supported by the Forschungszentrum Jülich (COSY-FEE), by the U.S. Department of Energy, Office of Science, Office of Nuclear Physics, under Award Number DE.FG02.99ER41110, and by the Shota Rustaveli Science Foundation Grant.

[1] R.A. Arndt, I.I. Strakovsky, R.L. Workman, Phys. Rev. C 62 (2000) 034005; R.A. Arndt, W.J. Briscoe, I.I. Strakovsky, R.L. Workman, Phys. Rev. C 76 (2007) 025209; <http://gwdac.phys.gwu.edu>.
 [2] D. Albers et al., Phys. Rev. Lett. 78 (1997) 1652; D. Albers et al., Eur. Phys. J. A 22 (2004) 125 .
 [3] M. Altmeier et al., Phys. Rev. Lett. 85 (2000) 1819 ; M. Altmeier et al., Eur. Phys. J. A 23 (2005) 351.
 [4] F. Bauer et al., Phys. Rev. Lett. 90 (2003) 142301; F. Bauer et al., Phys. Rev. C 71 (2005) 054002.
 [5] S. Barsov et al., Nucl. Instrum. Methods A 462 (2001) 364 .
 [6] R. Maier et al., Nucl. Instrum. Methods A 390 (1997) 1 .
 [7] R. Schleichert et al., IEEE Trans. Nucl. Sci. 50 (2003) 301.
 [8] S. Dymov et al., Part. Nucl. Lett. 2(119) (2004) 40.
 [9] A. Khoukaz et al., Eur. Phys. J. D 5 (1999) 275.
 [10] Z. Bagdasarian, S. Dymov, and G. Macharashvili, ANKE internal reports

available from

collaborations.fz-juelich.de/ikp/anke/internal.shtml.
 [11] P.D. Eversheim et al., AIP Conf. Proc. 293 (1993) 92.
 [12] D. Chiladze et al., Phys. Rev. ST Accel. Beams 9 (2006) 050101.
 [13] A. Lehrach et al., AIP Conf. Proc. 675 (2003) 153.
 [14] E. Weise, PhD thesis, University of Bonn, 2000.
 [15] G.G. Ohlsen, P.W. Keaton Jr., Nucl. Instrum. Methods 109(1973) 41.
 [16] S. Yaschenko et al., Phys. Rev. Lett. 94 (2005) 072304.
 [17] M.W. McNaughton et al., Phys. Rev. C 23 (1981) 1128.
 [18] F. Irom, G.J. Igo, J.B. McClelland, C.A. Whitten, Phys. Rev. C 25 (1982) 373.
 [19] P.R. Bevington et al., Phys. Rev. Lett. 41 (1978) 384.
 [20] C.E. Allgower et al., Nucl. Phys. A 637 (1998) 231.
 [21] D. Chiladze, Proc. of Science (STORI'11) (2011) 039.